

**1. Forearm Balance (Mark position of trough pivot)**

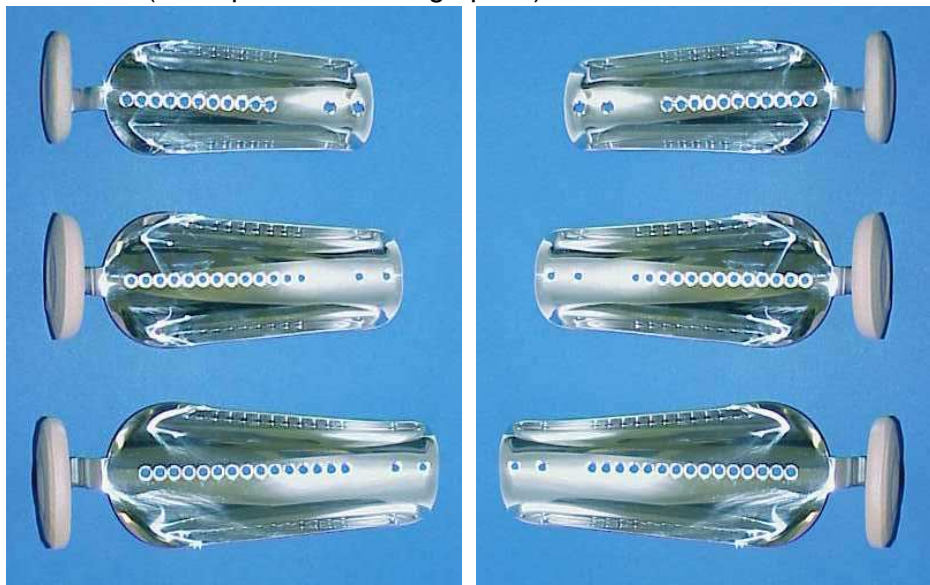

Left Trough

Right Trough

**2. Elevating MAS number of bands**

Hard  Soft

**3. Friction MAS Settings:**

	Free		3		5		7		Fixed	
Proximal Joint										
Elbow Joint										
Wrist Joint										
Trough Joint										
	0	2	4	6	8	10				

**4. Table MAS Positioning (mark dimension of clamp location)**

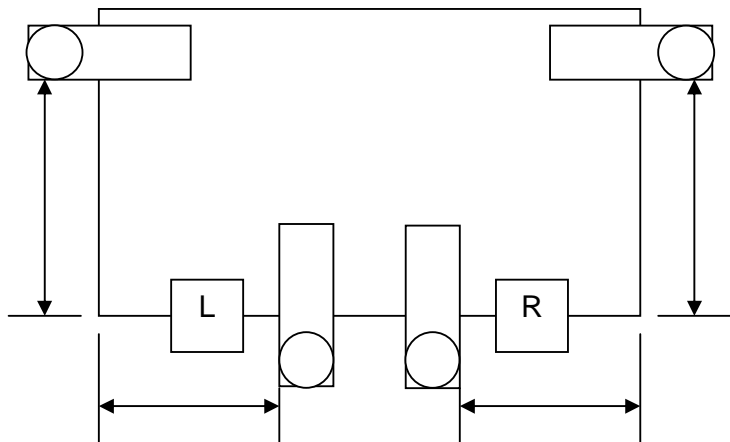

**4.1 Distal Arm L or R?**

**4.2 Proximal Arm Height**